

### Specifications

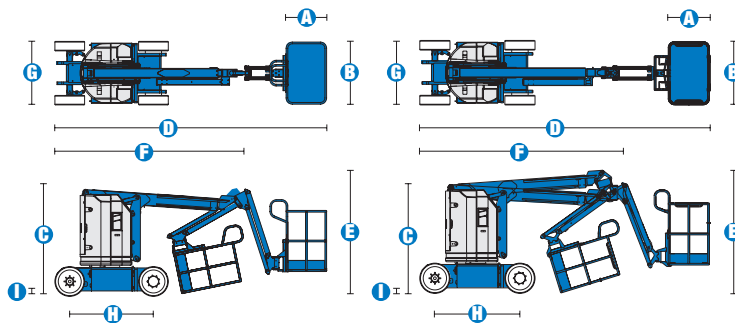

MODELS	Z™-30/20N		Z™-30/20N RJ	
	Metric	US	Metric	US
Working height maximum*	11.14 m	36 ft	10.89 m	35 ft 2 in
Platform height maximum	9.14 m	30 ft	8.89 m	29 ft 2 in
Horizontal reach maximum	6.53 m	21 ft 5 in	6.25 m	20 ft 6 in
Up-and-over clearance	3.86 m	12 ft 8 in	3.86 m	12 ft 8 in
<b>A</b> Platform length	76 cm	2 ft 6 in	76 cm	2 ft 6 in
<b>B</b> Platform width	1.17 m	3 ft 8 in	1.17 m	3 ft 8 in
<b>C</b> Height - stowed	2 m	6 ft 6.5 in	2 m	6 ft 6.5 in
<b>D</b> Length - stowed	5.11 m	16 ft 9 in	5.31 m	17 ft 5 in
<b>E</b> Storage height	2.08 m	6 ft 10 in	2.24 m	7 ft 4 in
<b>F</b> Storage length	3.5 m	11 ft 6 in	3.66 m	12 ft
<b>G</b> Width	1.19 m	3 ft 11 in	1.19 m	3 ft 11 in
<b>H</b> Wheelbase	1.60 m	5 ft 3 in	1.60 m	5 ft 3 in
<b>I</b> Ground clearance - centre	9 cm	3.5 in	9 cm	3.5 in

PRODUCTIVITY				
Lift capacity	227 kg	500 lbs	227 kg	500 lbs
Platform rotation	180°	180°	180°	180°
Vertical jib rotation	139°	139°	139°	139°
Horizontal jib rotation	—	—	180° (+72°/-67°)	180°
Turntable rotation	355° non-continuous		355° non-continuous	
Turntable tailswing	zero	zero	zero	zero
Drive speed - stowed	4.8 km/h	3.0 mph	4.8 km/h	3.0 mph
Drive speed - raised**	1.1 km/h	0.68 mph	1.1 km/h	0.68 mph
Gradeability***	35%	35%	35%	35%
Turning radius - inside	1.65 m	5 ft 5 in	1.65 m	5 ft 5 in
Turning radius - outside	3.23 m	10 ft 7 in	3.23 m	10 ft 7 in
Controls	24 V DC proportional		24 V DC proportional	
Tyres - solid non-marking	56x18x45 cm	22x7x17.75 in	56x18x45 cm	22x7x17.75 in

POWER				
Power source	48 V DC (Eight 6 V batteries 350 Ah capacity)		48 V DC (Eight 6 V batteries 350 Ah capacity)	
Auxiliary power unit	24 V DC	24 V DC	24 V DC	24 V DC
Hydraulic tank capacity	15.1 L	4 gal	15.1 L	4 gal

WEIGHT****				
	6,428 kg	14,170 lbs	6,450 kg	14,220 lbs

**STANDARDS COMPLIANCE** CE EN280, PB-10-611-03

\* The metric equivalent of working height adds 2 m to platform height. U.S. adds 6 ft to platform height.  
 \*\* In lift mode \*(platform raised), the machine is designed to operate on firm, level surfaces only.  
 \*\*\* Gradeability applies to driving on slopes. See Operator's Manual for details regarding slope ratings.  
 \*\*\*\* Weight will vary depending on options and/or country standards.

### RANGE OF MOTION Z™-30/20N

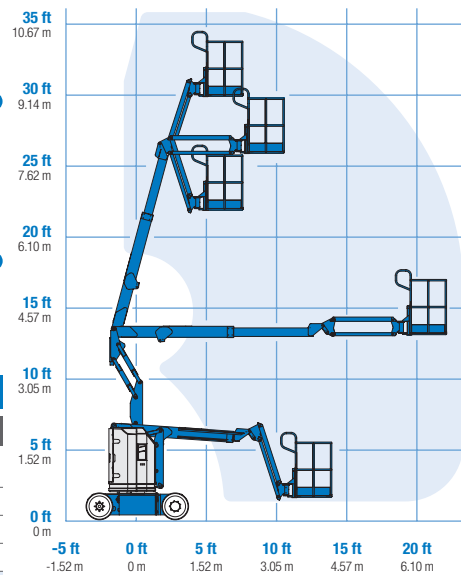

### RANGE OF MOTION Z™-30/20N RJ

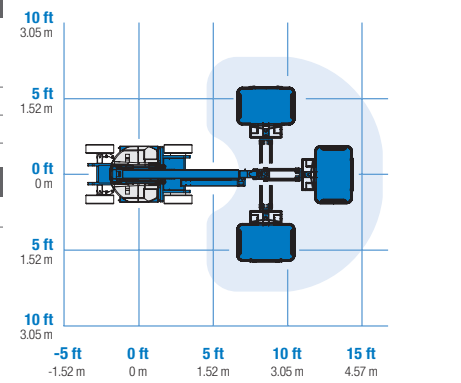
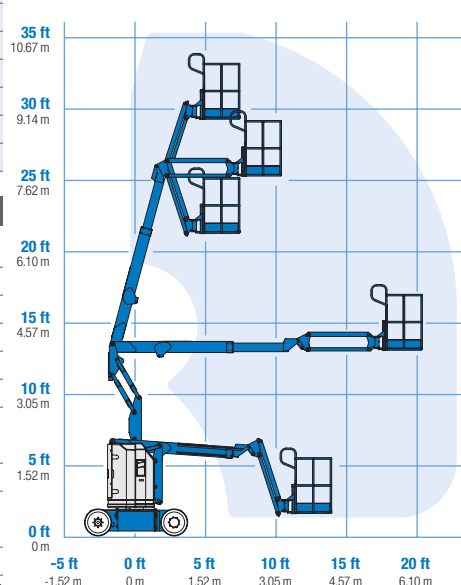



ERROR: undefined  
OFFENDING COMMAND: get

STACK:

/0  
-dictionary-  
1